



**AIR
SPIRALO®**

VENTILATION DUCTS & FITTINGS

Air Spiralo® RSR Rectangular rock wool silencer

Application

It is commonly accepted that 30dB(A) is the upper limit for noise pollution in housing but dynamic sound (rustle) and noise caused by air handling units, fans, diffusers or other components in a ventilation system can be higher than 30dB(A).

Prevention

Air Spiralo® manufactures a complete serie of circular and rectangular silencers with circular connections, bends and flexible silencers, all with a very low aero-dynamic resistance and unrivalled sound attenuation.

Unique features

- Highest possible sound attenuation combined with very low resistance
- Pressure loss circular silencer: same value as for standard duct with identical length
- Specially formed inner tube for highest sound attenuation
- Tested by an independent laboratory according to ISO 7235
- Innovative construction of inside and outside shell ensures no contactor noise
- Ideal aero-dynamics profile by the absence of corners and borders
- Low building height
- Openable or closed (standard) models
- Easy to clean with brushes, no sharp edges or dust pockets
- Standard insulation thickness 50 mm. Other thickness on request.
- A retaining fiber cloth prevents any particles entering the current of air
- KEN-LOK® connections with rubber seal
- Air tightness class D
- Sendzimir galvanized steel. Other lengths and/or material on request.



Order code:

RSRP012.030.11K

RS = Rectangular silencer
 R = Rock wool
 P = Perforated straight tube, F = Perforated formed tube
 012 = Diameter Ø125 mm
 030 = Length 300 mm, 060 = 600 mm, 100 = 1000 mm
 11 = Closed model, 12 = Openable model
 K = KEN-LOK® rubber seal



Dimensions RSR, closed model (11) / openable model (12)

RSR-type	Dimensions (mm)						Attenuation ΔL (dB) / Octaves (Hz)							
	$\varnothing d_1$	l_1	l_{b1}	a_1	b_1	b_2	63	125	250	500	1000	2000	4000	8000
RSRP010.030.11(12)K	100	300	48	262	152	75	8	10	14	24	26	24	18	11
RSRF010.060.11(12)K	100	600	48	262	152	75	17	20	24	40	52	50	36	23
RSRF010.100.11(12)K	100	1000	48	262	152	75	21	22	29	49	60	57	48	32
RSRP012.030.11(12)K	125	300	48	272	178	88	7	9	13	22	24	21	17	10
RSRF012.060.11(12)K	125	600	48	272	178	88	16	17	22	37	50	48	33	21
RSRF012.100.11(12)K	125	1000	48	272	178	88	17	18	27	47	59	54	43	30
RSRP015.030.11(12)K	150	300	48	292	212	105	6	9	12	20	22	19	15	10
RSRP015.060.11(12)K	150	600	48	292	212	105	14	15	19	33	46	44	28	19
RSRP015.100.11(12)K	150	1000	48	292	212	105	14	16	25	43	57	51	38	24
RSRP016.030.11(12)K	160	300	48	292	212	105	6	9	12	20	22	19	15	10
RSRF016.060.11(12)K	160	600	48	292	212	105	14	15	19	33	46	44	28	19
RSRF016.100.11(12)K	160	1000	48	292	212	105	14	16	25	43	57	51	38	24
RSRP018.030.11(12)K	180	300	48	373	255	127	6	8	11	16	18	16	13	9
RSRP018.060.11(12)K	180	600	48	373	255	127	14	15	17	30	41	38	26	17
RSRP018.100.11(12)K	180	1000	48	373	255	127	16	16	24	41	53	48	34	22
RSRP020.030.11(12)K	200	300	48	373	255	127	6	8	11	16	18	16	13	9
RSRF020.060.11(12)K	200	600	48	373	255	127	14	15	17	30	41	38	26	17
RSRF020.100.11(12)K	200	1000	48	373	255	127	16	16	24	41	53	48	34	22
RSRF025.060.11(12)K	250	600	58	442	302	150	13	14	16	28	38	33	19	12
RSRF025.100.11(12)K	250	1000	58	442	302	150	14	15	22	37	51	44	28	19
RSRF031.060.11(12)K	315	600	58	470	370	184	13	13	15	25	34	27	16	9
RSRF031.100.11(12)K	315	1000	58	470	370	184	13	14	20	32	44	36	25	17
RSRF040.060.11(12)K	400	600	58	532	452	225	10	11	13	23	30	20	14	8
RSRF040.100.11(12)K	400	1000	58	532	452	225	11	12	17	32	39	23	17	13
RSRP050.060.11(12)K	500	600	58	713	587	278	4	7	9	17	20	11	9	6
RSRP050.100.11(12)K	500	1000	58	713	587	278	6	10	14	24	28	17	12	8
RSRP063.060.11(12)K	630	600	58	864	687	343	3	6	7	11	12	8	7	5
RSRP063.100.11(12)K	630	1000	58	864	687	343	5	9	12	19	21	14	11	5

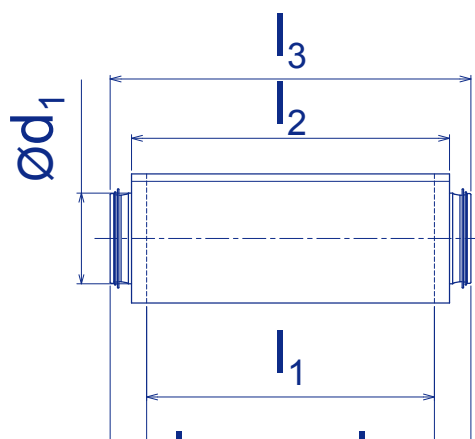

closed model (11)

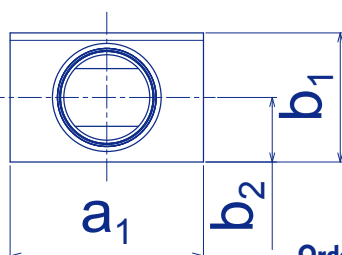

openable model (12)

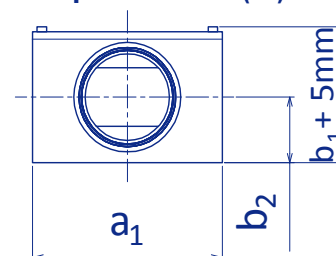

Orders and requests for quotation: sales@airspiralo.com
 For additional information: www.airspiralo.com

Pressure loss (ISO 5167), RSRF ($I_1=600$)

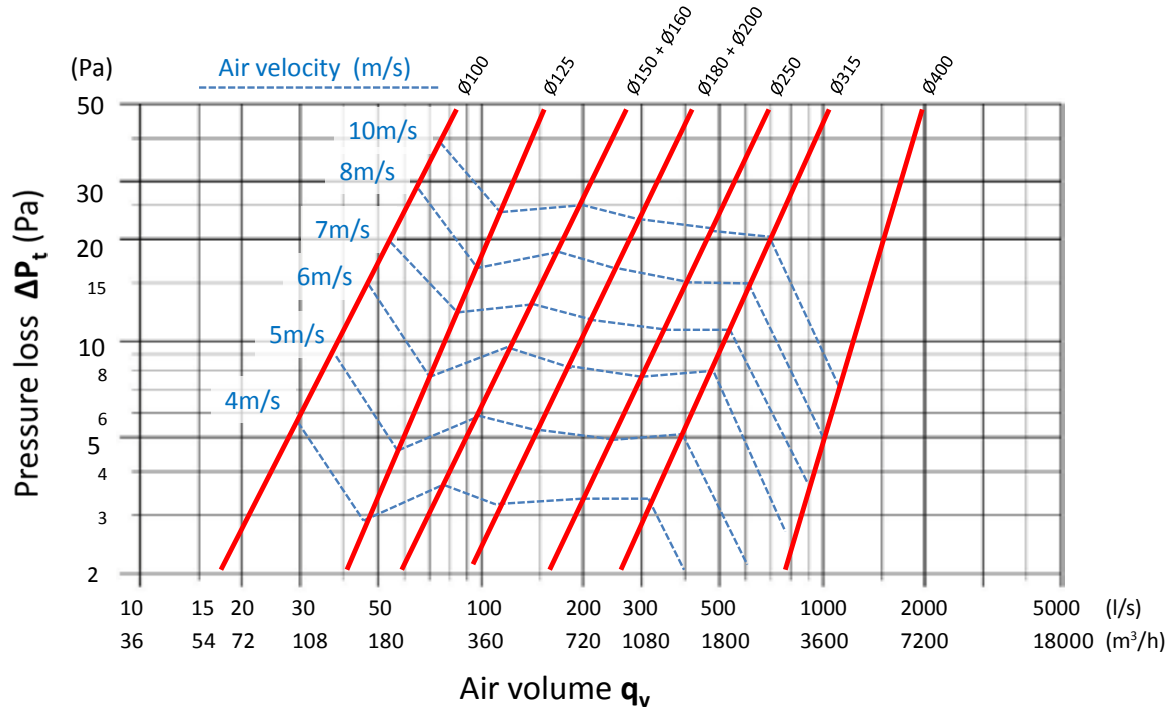

Pressure loss (ISO 5167), RSRF ($I_1=1000$)

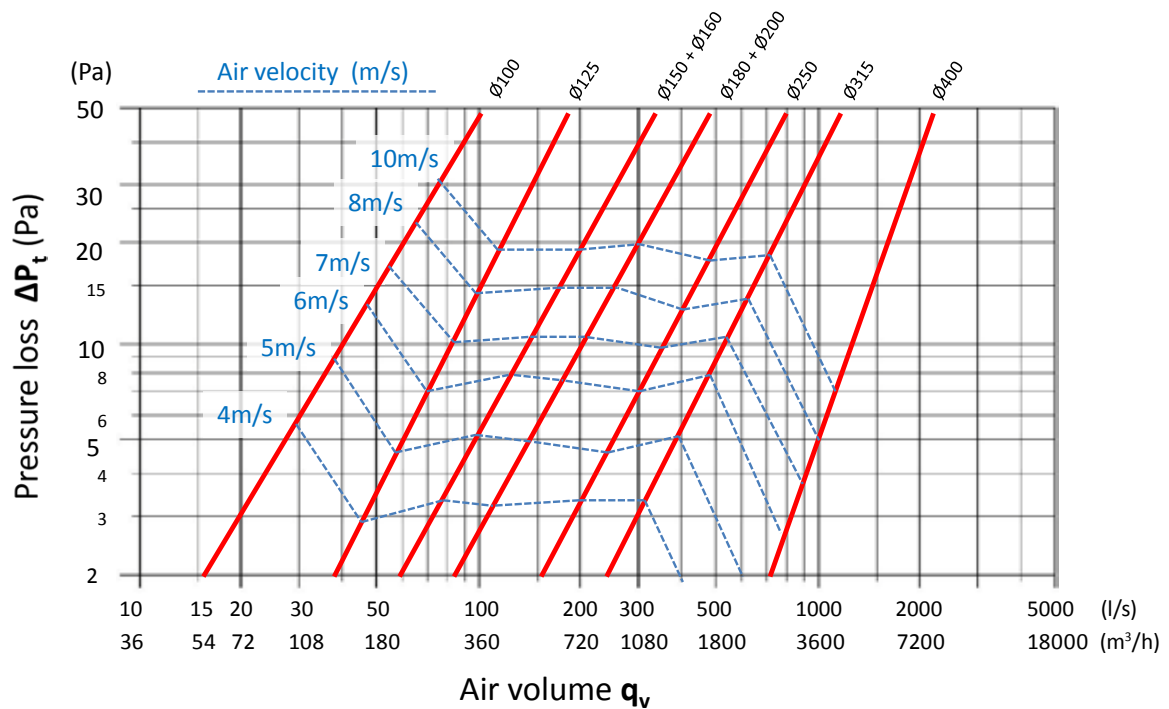



VENTILATION DUCTS & FITTINGS

Air Spiralo® KEN-LOK®

Ducts and fittings

Dampers

Silencers

Access doors

Damp-proof ducts and fittings

Fire dampers

Isolated ducts and fittings

Marine insulated ducts and fittings

Air Spiralo®

Rectangular ducts and fittings

Finishing Panels

Ventilation hoods

Flexible ducts

Components

Mounting material

Ducting ancillaries

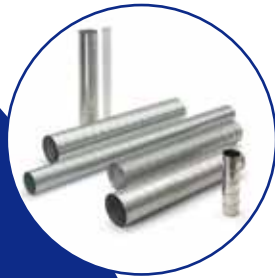

Air Spiralo® • Kennemer Schagen Industries BV

P.O. Box 51 • 1740 AB Schagen • The Netherlands

T +31 224 210067 • F +31 224 216 545 • info@airspiralo.com • www.airspiralo.com